

**Modello: CH-2/R13D**

Engine	
Engine model	Kubota Z-482
Max Power (3600 rpm)	Hp / Kw 13 / 9.6
Cooling	Water
Start	Electric
Battery	12V – 44Ah
Displacement	479 cm <sup>3</sup>
Cylinders	2
Max Torque	3.00 daNm - 2600 rpm
Operational weight	
Under carriage	485 Kg
CH-2/R/CA alluminium platform	555 Kg
CH-2/R/C-CP body with front door	570 / 645 Kg
CH-2/R/MT-MTP dumping skip	580 / 650 Kg
CH-2/R/AV-AVP high tip skip	690 / 775 Kg
CH-2/R/BET mixer	730 Kg
CH-2/R/ESC hydraulic backhoe	775 Kg
Operational loading	
All versions	500 Kg
CH-2/R/AV-AVP	450 Kg
Road transportable load	
All versions	800 Kg
Features	
Transmission	Hydrostatic
Transmission pumps with variable cubic capacity	n° 2
Total delivery	27.7 lt/min
Gear pump flow	6.8 lt/min
Max working pressure utilities	150 bar
Max speed	4.2 Km/h
Rubber track tensioning: adjustable screw + spring	•
Steering through independent tracks and negative brakes	•
Track width	180 mm
Max gradient capability with operational loading	30.00%
Refuelling	
Fuel tank capacity	10 lt
Hydraulic oil tank capacity	20 lt

# Dumper MESSERSI CH-2/R13D

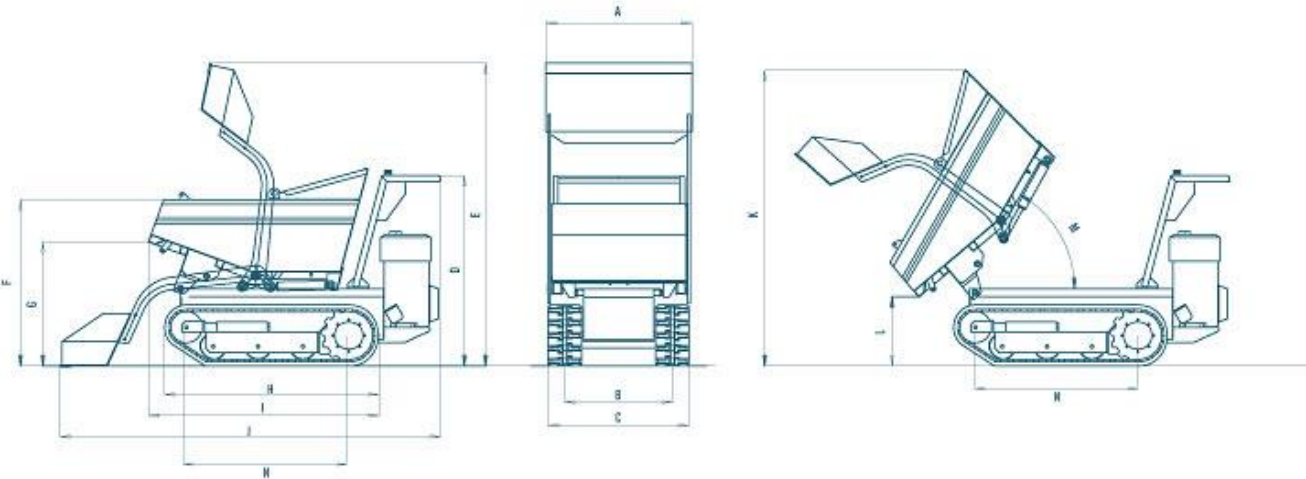

TIPO	A	B	C	D	E	F	G	H	I	J	K	L	M	N
CH-2/R/MT-MTP	830	610	790	1270	1720	940	700	1240	1310	2160	1670	400	60°	920